



# Quick Installation Guide

PV Grid-Tied Inverter









SL30KRG-W | SL33KRG-W | SL36KRG-W | SL40KRG-W | SL50KRG-W

- This Guide could be updated and modified due to product upgrades or other reasons, and it does not replace the User Manual and safety instructions for the product under any circumstances.
- Before operation, please read the User Manual and More information is available on [www.slenergy.com](http://www.slenergy.com) or the manufacturer's website.
- All operations must be performed by qualified technicians who have read the User Manual, master the safety precautions related to operation, and are familiar with local standards and relevant safety regulations of the electrical system.
- The cables in the photovoltaic power generation system must be intact and well-insulated. Use insulation tools and wear protective equipment when operating them.
- Slenergy assumes no liability for injury or property damage due to repairs attempted by unqualified individuals or a failure to properly follow this Guide.
- All information and recommendations provided herein do not constitute an express or implied warranty, the final interpretation of the relevant content shall be vested solely in Slenergy.

### The packing list is as follows:

Name	Quantity	Name	Quantity
Inverter	1	AC Waterproof Cover	1
Wall Mount	1	16Pin Communication Connection	1
DC Connectors (pairs)	6/6/6/8/8	Accessory Kit of Installing Screw	1
OT Terminals	6	Quick Installation Guide	1
AC Waterproof Lock	1	Passport	1

### Important Safety Instruction

- 
 Switch off the machine before any operation and maintenance.
- 

 Before wiring and checking, ensure that the DC/AC circuit breakers of inverter have been disconnected and wait at least 5 minutes.
- 
 Do not expose this machine to ambient temperatures above 60°C(140°F) or below -25°C(-13°F).
- 
 Read the Manual before any operations on the inverter.
- 
 Exposed wiring and operation during powering on can present a risk of electrical shock.
- 
 Reliably earth the inverter for protective grounding.

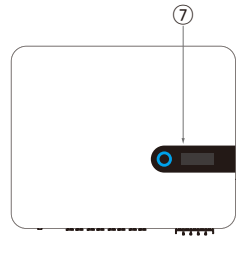
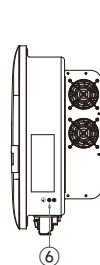
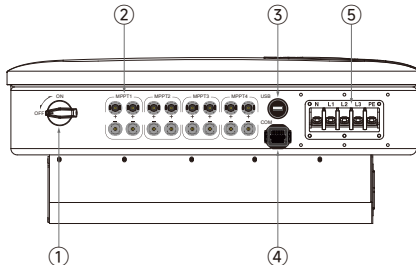
### Product Overview

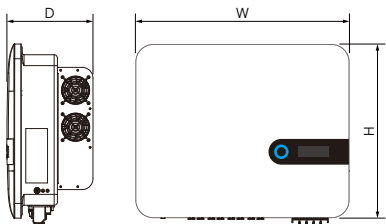

- ① DC switch
- ② DC input terminals
- ③ USB interface
- ④ Communication terminal
- ⑤ AC wiring port
- ⑥ External grounding terminal
- ⑦ LED indicator and LCD screen

## Dimension & Weight



Models	Dimension (W×H×D)	Weight
SL30-40KRG-W	590 x 480 x 237mm	34kg
SL50KRG-W	590 x 480 x 237mm	36kg

## Installation Site

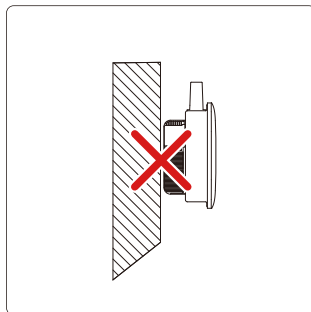
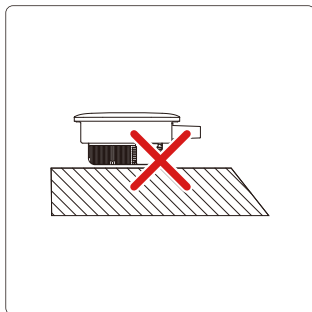
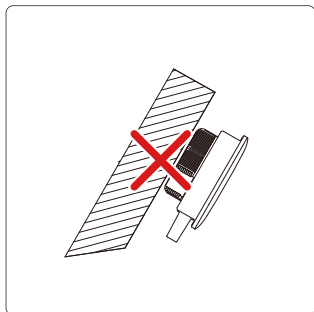
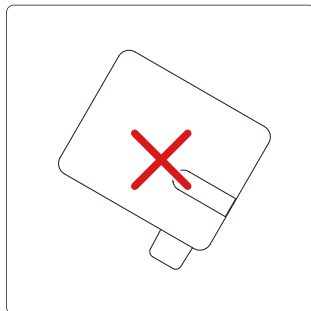
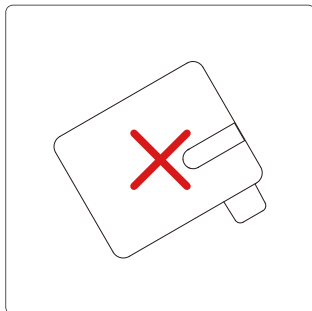
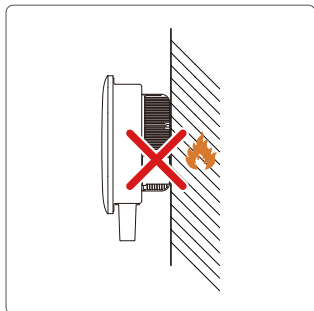
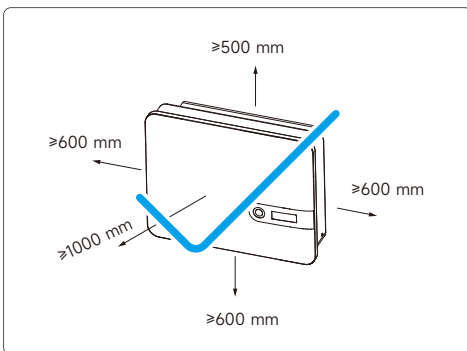
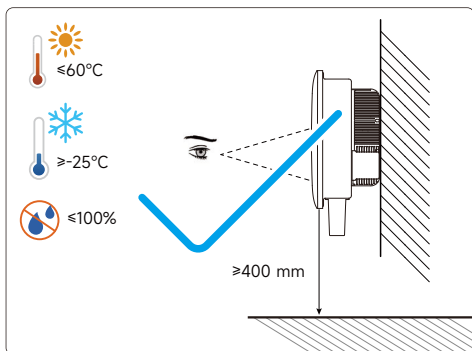

## Installation Steps

Before drilling, avoid the electrical wiring inside the wall to prevent danger!

Place the hanging plate flush on the wall, mark the recommended holes as shown, and drill the holes to a depth of about 70 mm.

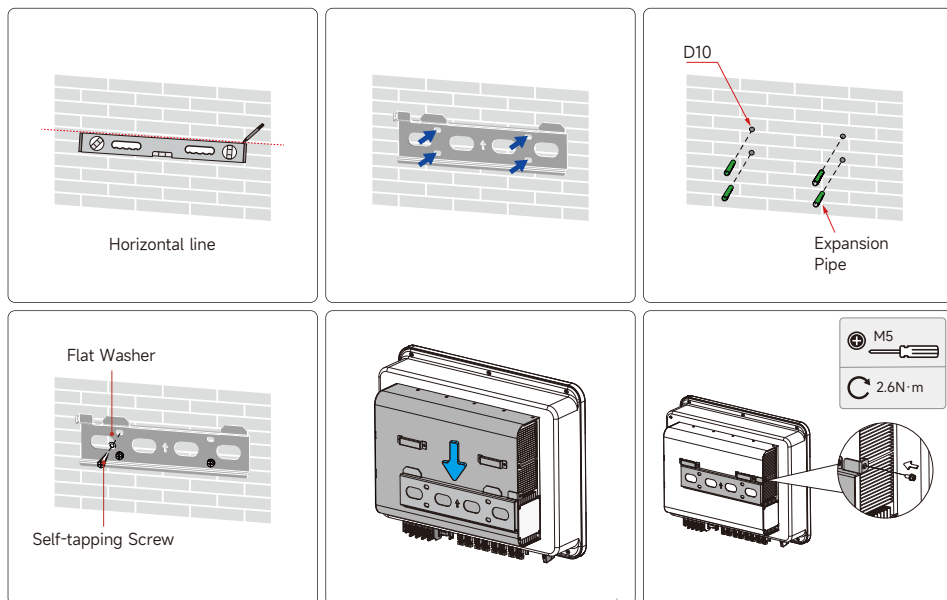

## External Grounding Connection

In PV systems, all non-current-carrying metal parts and equipment enclosures shall be grounded (e.g. PV brackets, inverter enclosures).

For a single inverter, the inverter PE cable shall be grounded, and for multiple inverters, all the inverter PE cables and the PV array metal structure shall be connected to an equipotential line to ensure equipotential connection.

- Note:**
1. Separate the safety grounding of the equipment from the lightning protection grounding, and keep the distance between them as far as possible.
  2. After the grounding cable is fixed, apply silicone gel or paint on the grounding terminal to improve its anti-corrosion performance.
  3. Tighten the screws for grounding the enclosures with a torque of 1.2 N.m to 2 N.m.

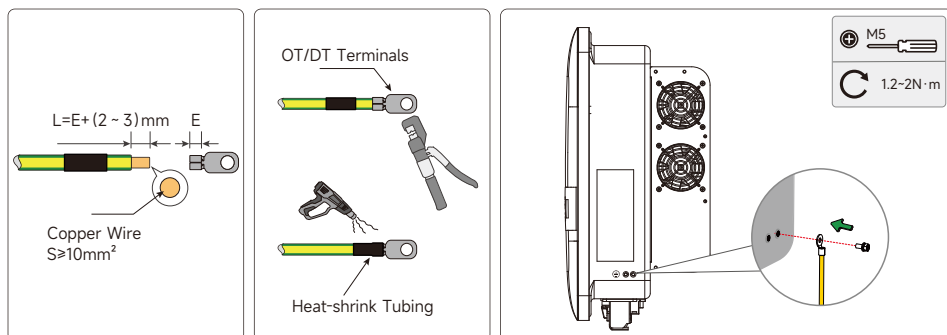

## AC-side Wiring

Before connecting the AC side to grid, the grid voltage and frequency shall comply with the requirements of the inverter. See Technical Data for detailed parameters. If not, users shall contact the power utility company for resolution.

Inverter Model	Recommended AC circuit breaker parameters
SL30KRG-W	63A
SL33KRG-W, SL36KRG-W	80A
SL40KRG-W	100A
SL50KRG-W	125A



**CAUTION**

- Inverters may be connected to the grid only with the access permission from of the local power utility company.
- Multiple inverters shall not share a single AC circuit breaker.
- No load shall be connected between the inverter and AC circuit breaker.

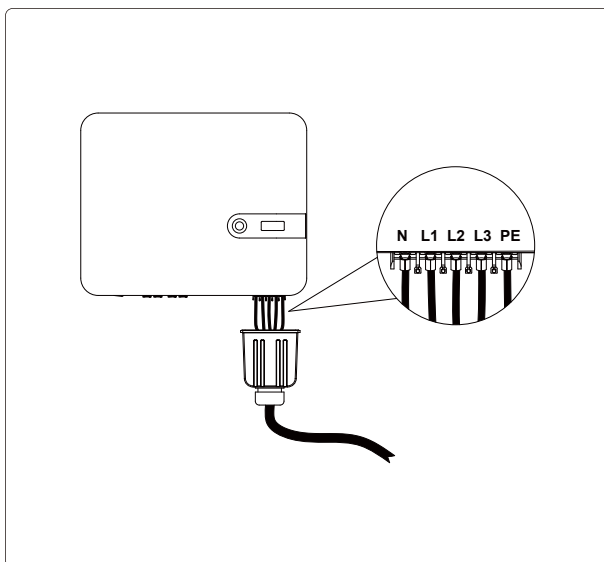
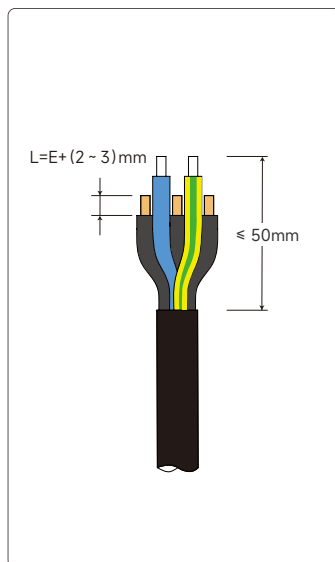

### **CAUTION**

Pay much attention to the positioning of the "PE" cable and "N" cable. If the phase wire is connected to the terminal of "PE" or "N" cable, the inverter may be damaged.

## DC-side Connection

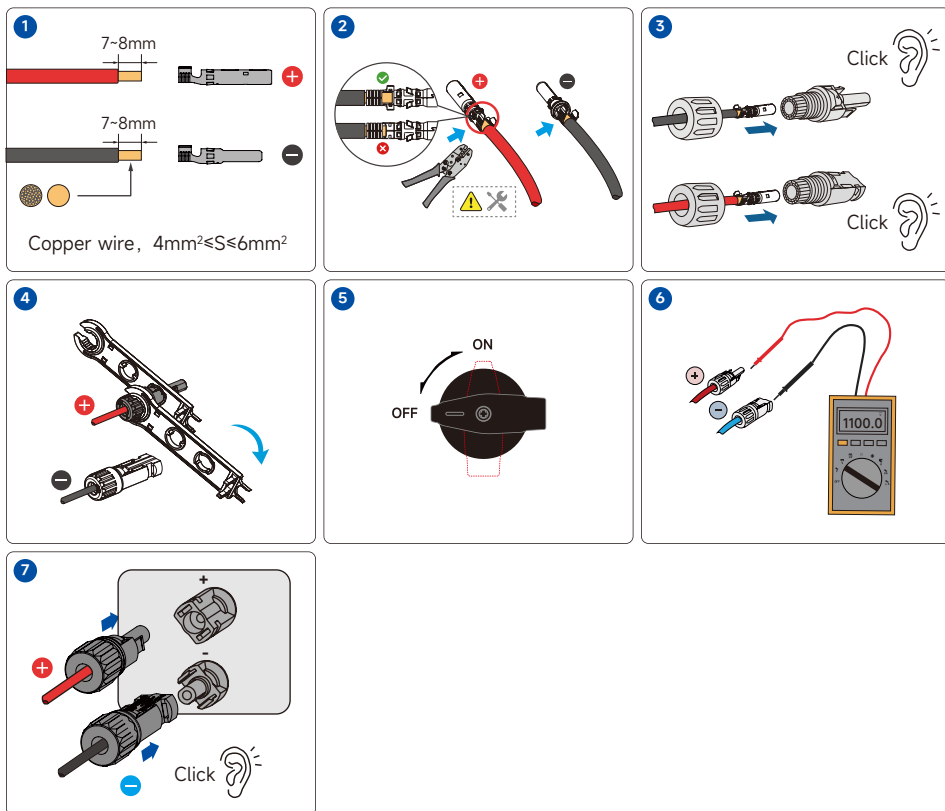

## Inspection Before Commissioning

S/N	Inspection Item	Inspection Result	
		Normal	Abnormal
1	Check and confirm that all equipment is reliably installed.	<input type="checkbox"/>	<input type="checkbox"/>
2	Check if the DC switch and AC breaker are in "OFF".	<input type="checkbox"/>	<input type="checkbox"/>
3	Check the ground wire for proper connection.	<input type="checkbox"/>	<input type="checkbox"/>
4	Check the AC cable for proper connection.	<input type="checkbox"/>	<input type="checkbox"/>
5	Check the DC cable for proper connection.	<input type="checkbox"/>	<input type="checkbox"/>
6	Check the communication cable for proper connection.	<input type="checkbox"/>	<input type="checkbox"/>
7	Check if vacant terminals are sealed.	<input type="checkbox"/>	<input type="checkbox"/>
8	Ensure that no construction tools are left on top of the equipment or inside the wiring box (if any).	<input type="checkbox"/>	<input type="checkbox"/>
9	Select AC circuit breakers as per the Manual and local standards.	<input type="checkbox"/>	<input type="checkbox"/>
10	Ensure that all safety signs and warning labels are fixed and visible.	<input type="checkbox"/>	<input type="checkbox"/>

## Communicating Connection

- The wireless communication module is installed to the communication accessory port (silkscreen marked USB) at the bottom of inverter.
- Via the communication accessory port, users can access the Wi-Fi wireless communication module from our company. You can check the power generation and operation status of inverter through the mobile App after successful connection.



Please see the Manual shipped with the module for its detailed installation and configuration as well as the supporting App.

## Commissioning Steps

- STEP 1** Rotate the DC switch on the inverter to "ON".
- STEP 2** Turn on the AC switch if it is configured between the inverter and grid.
- STEP 3** Turn on the DC switch if it is configured between the inverter and PV string.
- STEP 4** Ensure that the light is proper and meet the requirements for grid connection to make the inverter operate normally.
- STEP 5** Observe the status of LED indicator (and see LED Indicator for details).

## LED Indicator

LED indicator + LCD screen, a human-machine interface on the front panel of inverter, may display the current inverter status.

Indicator	Status	Meaning
	Steady <b>Blue</b>	The inverter is in grid-connected mode.
	Blinking <b>Blue</b> at 0.2s intervals	USB is connected with data communication and the inverter is free of faults.
	Blinking <b>Blue</b> at 2s intervals	DC or AC is on, and the inverter is in standby or start-up mode (non-grid-connected mode).
	Steady <b>Green</b>	PID enabled.
	Blinking <b>Green</b> at 0.2s intervals	The inverter is downloading programs.
	Steady <b>Red</b>	The inverter is faulty.
	Blinking <b>Red</b>	USB is connected with data communication and the inverter is faulty.
	<b>Off</b>	AC and DC or DC only are/is off.

### CAUTION

- If the commissioning fails, please refer to the troubleshooting in the User Manual.
- Please refer to the module manual for an explanation of indicator lights in the communication module.

TEL:

**400-826-5788**

EMAIL:

service@slenergy.com



**Slenergy Technology (A.H.) Co., Ltd.**

Add.: No.120 Yongyang Road, Chuzhou City, Anhui, P.R. China

As the dimension and parameter of products change, the latest information of our company shall prevail without prior notice.

SL30-50KRG-W Quick Installation Guide-20240531C1



Smart M



[www.slenergy.com](http://www.slenergy.com)