

Quick Installation Guide

Three-phase Hybrid Solar Inverter



SL5KRH-W | SL6KRH-W | SL8KRH-W | SL10KRH-W | SL12KRH-W

- This Guide could be updated and modified due to product upgrades or other reasons, and it does not replace the User Manual and safety instructions for the product under any circumstances.
- Before operation, please read the User Manual and More information is available on www.slenergy.com or the manufacturer's website.
- All operations must be performed by qualified technicians who have read the User Manual, master the safety precautions related to operation, and are familiar with local standards and relevant safety regulations of the electrical system.
- The cables in the photovoltaic power generation system must be intact and well-insulated. Use insulation tools and wear protective equipment when operating them;
- Slenergy assumes no liability for injury or property damage due to repairs attempted by unqualified individuals or a failure to properly follow this Guide.
- All information and recommendations provided herein do not constitute an express or implied warranty, the final interpretation of the relevant content shall be vested solely in Slenergy.

The packing list is as follows:

Name	Quantity	Name	Quantity
Inverter	1	16pin Communication Connection	1
Wall Mounting Bracket	1	Back up AC Quick Connector	1
External CT	3	GRID AC Quick Connector	1
Datalogger	1	Quick Installation Guide	1
PV DC Connector (pair)	3	Factory Inspection Report	1
BAT DC Connector (pair)	1	Screw Mounting Kit	1
3m Network Cables and Waterproof Connectors			1

Important Safety Instruction

- Switch off the machine before any operation and maintenance.
- Do not expose this machine to ambient temperatures above 60°C(140°F) or below -30°C(-22°F).
- Exposed wiring and operation during powering on can present a risk of electrical shock.
- Before wiring and checking, ensure that the DC/AC circuit breakers of inverter have been disconnected and wait at least 5 minutes.
- Read the Manual before any operations on the inverter.
- Reliably earth the inverter for protective grounding.

Product Overview

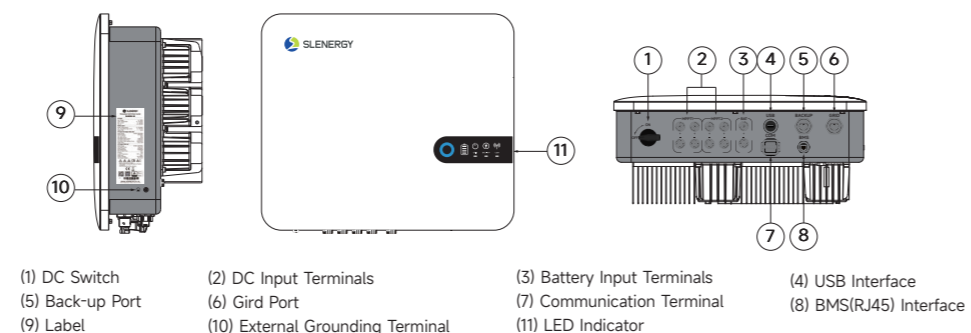

Dimension & Weight

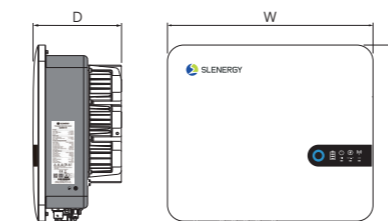

Models	Dimension (W×D×H)	Weight
SL5-12KRH-W	516 x 222 x 442mm	24kg

Installation Site

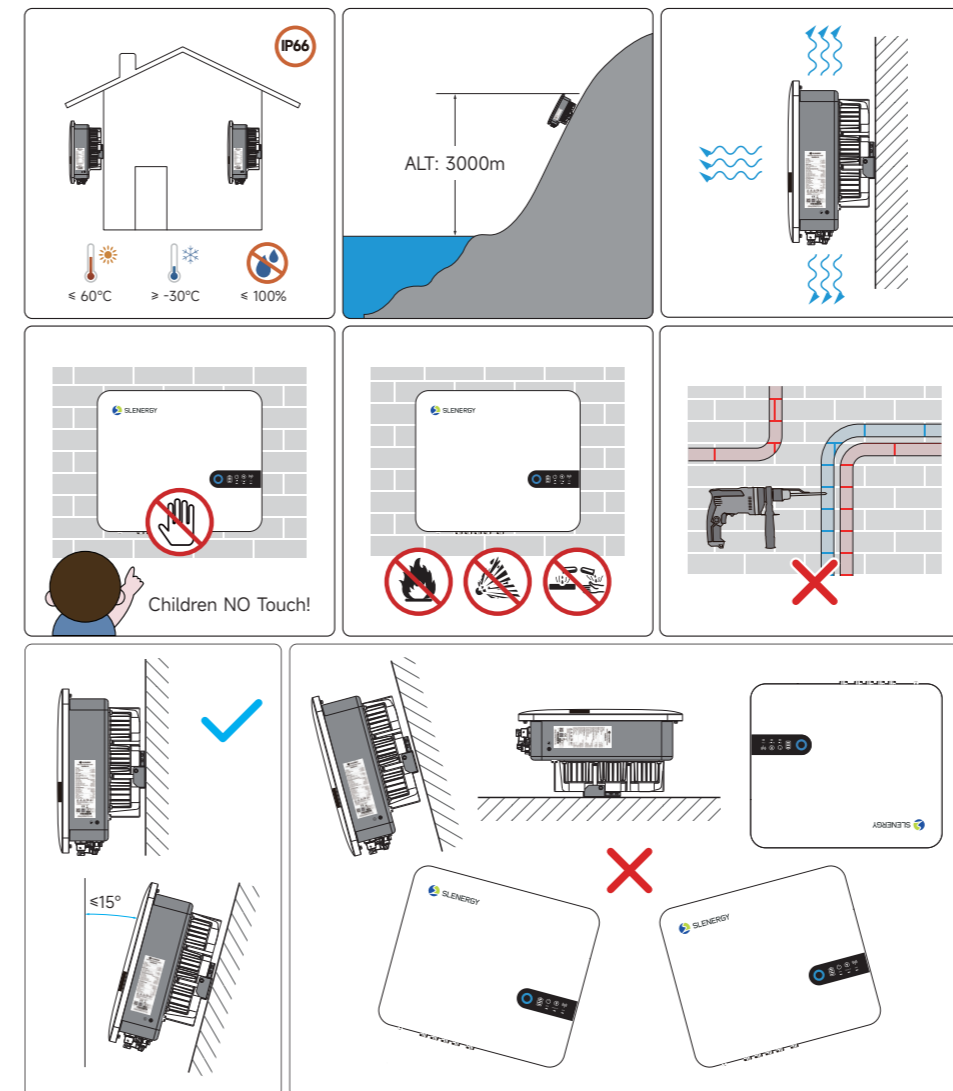

LED Indicators

The LED on the front panel of the inverter indicate the current working status of the inverter.

Indicator	Status	Indication
	Steady Blue	The inverter is in Grid-connected mode.
	Blinking Blue at 2s intervals	DC or AC is on, and the inverter is in standby or Start-up mode.
	Steady Yellow	The inverter is Alarm.
	Blinking Yellow at 0.2s intervals	Program download/upgrade.
	Steady Red	The inverter is faulty.
	Steady White	It indicates battery level.
	Blinking White at 2s intervals	The BMS experiences a communication failure or abnormal. (battery internal overtemperature, overcurrent, etc.)
	Off	The battery is not connected.
	Steady White	The power grid is normal.
	Blinking White at 0.2s intervals	The power grid is abnormal, and the grid connection is not accessible.
	Off	The grid is not connected.
	Steady White	There is a normal voltage in the back-up output port.
	Blinking White at 0.2s intervals	The inverter is overload.
	Off	There is no voltage in the back-up output port.
	Steady White	Wifi/4G/BMS communication is normal.
	Blinking White at 0.2s intervals	No communication module is installed or the communication is abnormal.

NOTICE

When the indicator is off, it may be in poor contact but may still be energized. Therefore, it is very necessary to pay attention to electrical safety when you need operate the inverter.

Slenergy Technology (A.H.) Co., Ltd.

Email: service@slenergy.com

Tel: 400-826-5788

SL5-12KRH-W Quick Installation Guide-20240228A1



Installation Steps

Before drilling, avoid the electrical wiring inside the wall to prevent danger!
Place the hanging plate flush on the wall, mark the recommended holes as shown, and drill the holes to a depth of about 70 mm.

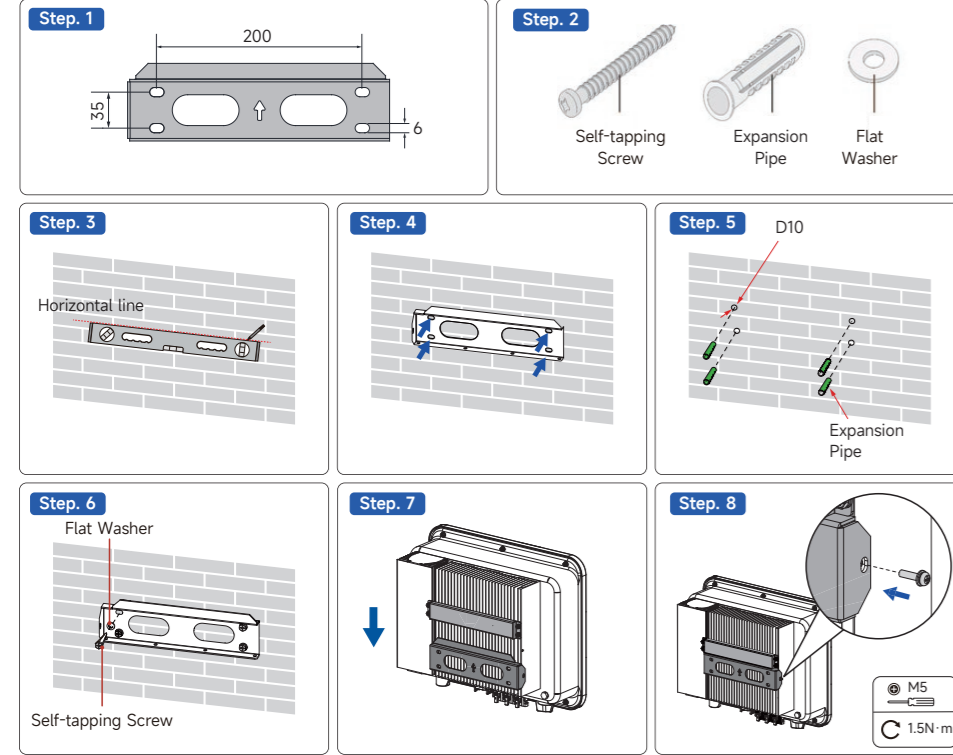

External Grounding Connection

- Since the inverter is transformer free, both the positive and negative poles of the PV string cannot be grounded, otherwise the inverter would not function properly.
- An external grounding connection is required before PV string and communication connections on the AC side.
- The grounding connection of the external protection grounding terminal cannot replace the PE terminal connection in the AC wiring. It shall be ensured that both of them are reliably grounded. Otherwise, Slenergy shall not be liable for any consequences that may occur.

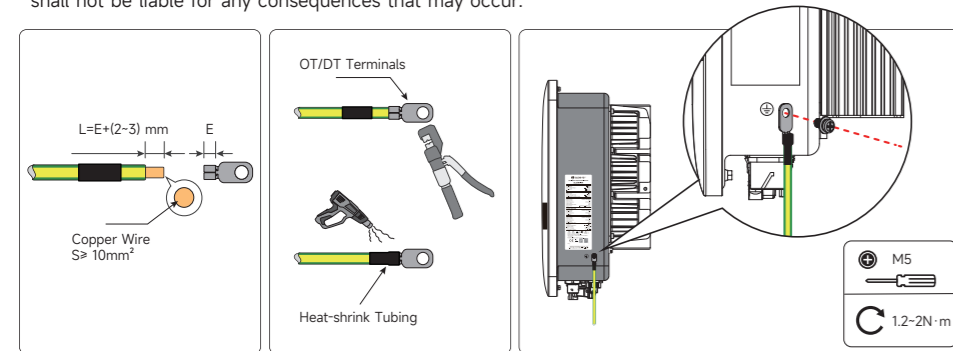

AC-side Connection (BACK-UP & GRID)

Requirements on AC Side

Before connecting to the power grid, please ensure that the power grid voltage and frequency meet the requirements of the inverter. Please see "Technical Data" for details, or contact the power company to solve the problem.

⚠ NOTICE

Inverters can only be connected to the grid with access permission by the local power company.

AC Circuit Breaker

An independent circuit breaker is configured on the AC side of each inverter to safely disconnect the inverter from the power grid. Recommended AC circuit breaker parameters are 63A / 400V.

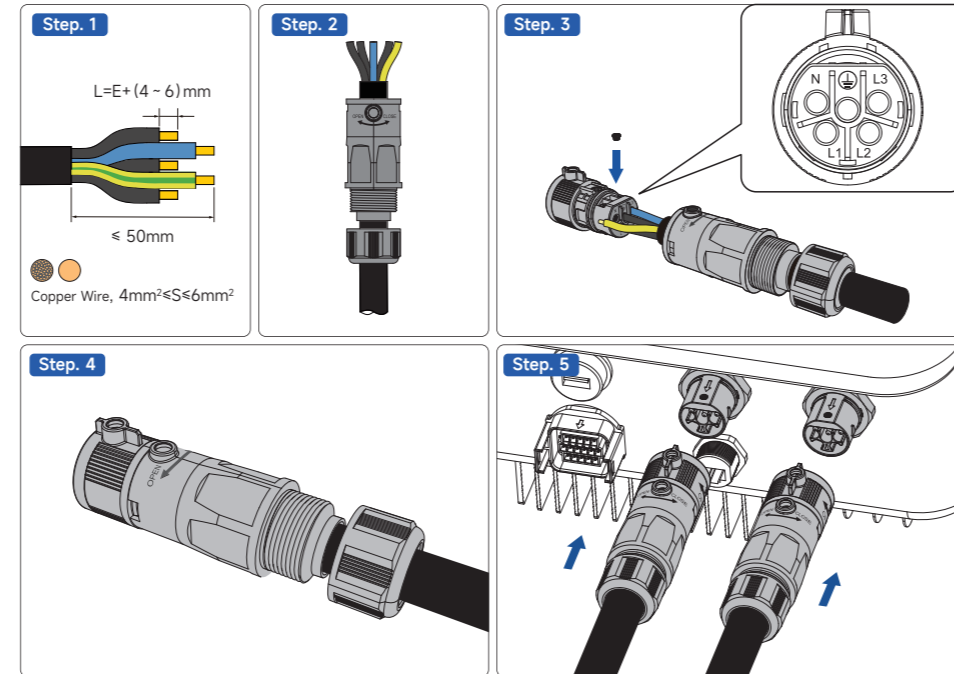

NOTICE

- Position of the PE cable and the N cable. If the phase wire is connected to the PE or N terminals, the inverter may be irreversibly damaged.
- Please ensure that the cable core is fully connected to the terminal wiring hole without any exposure.
- Please ensure that cables are securely connected. Otherwise, the terminal may overheat, causing damage to the device during operation.
- Ensure that the phase sequence of the mains and the machine is consistent, otherwise the machine will alarm and will not allow the mains to be connected.

DC-side Connection (PV & BAT)

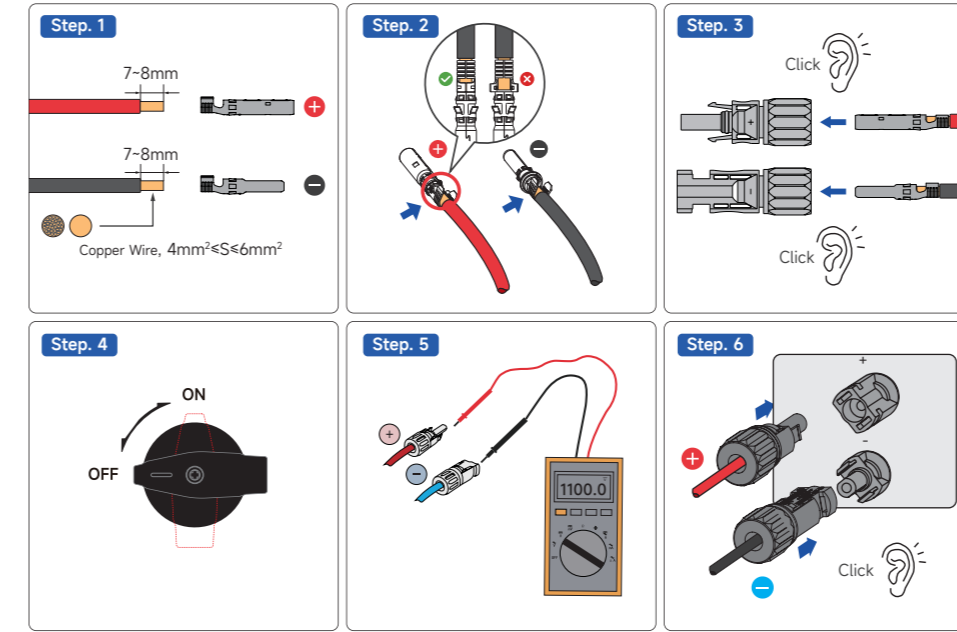

Communication Cable Connection

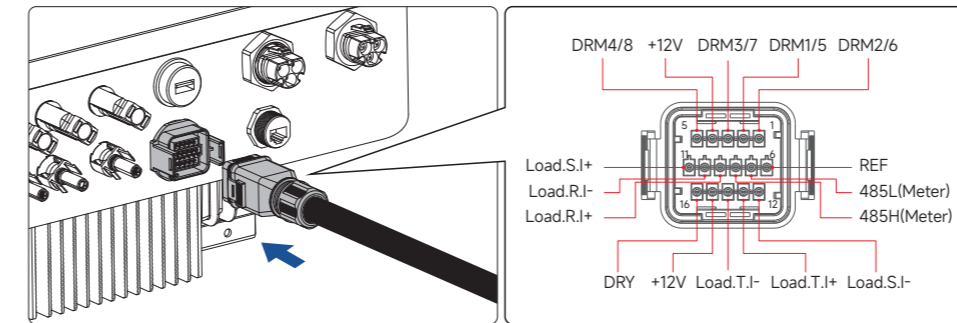

Datalogger Installation

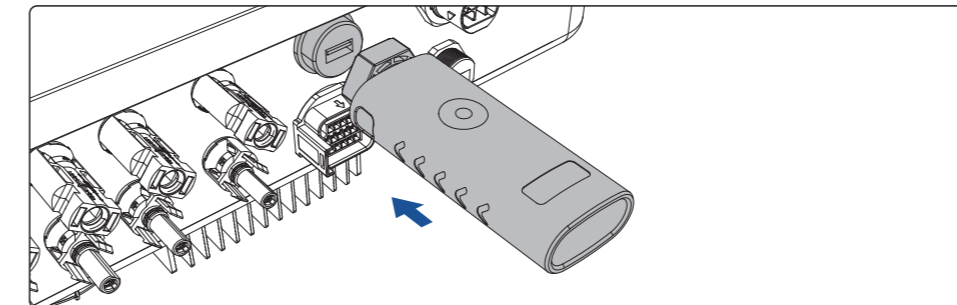

BMS Cable Connection

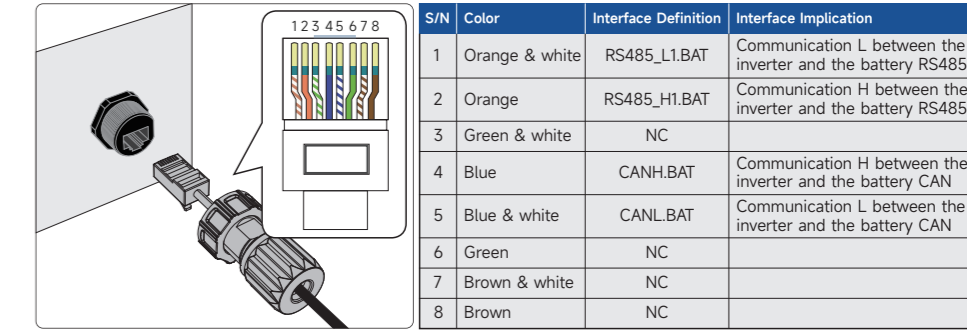

Pre-commissioning Checks

S/N	Inspection Item	Inspection Result	
		Normal	Abnormal
1	Check and confirm whether all equipment is reliably installed in place.	<input type="checkbox"/>	<input type="checkbox"/>
2	Check whether the DC switches and AC circuit breakers are "OFF".	<input type="checkbox"/>	<input type="checkbox"/>
3	Check whether the grounding lines are properly and reliably connected.	<input type="checkbox"/>	<input type="checkbox"/>
4	Check whether the AC cables are properly and reliably connected.	<input type="checkbox"/>	<input type="checkbox"/>
5	Check whether the DC cables are properly and reliably connected.	<input type="checkbox"/>	<input type="checkbox"/>
6	Check whether the communication cables are properly and reliably connected.	<input type="checkbox"/>	<input type="checkbox"/>
7	Check whether the vacant terminals are sealed.	<input type="checkbox"/>	<input type="checkbox"/>
8	Make sure that no construction tools, etc. are left on top of the machine or in the junction box (if any).	<input type="checkbox"/>	<input type="checkbox"/>
9	Select AC circuit breakers as per the Manual and local standards.	<input type="checkbox"/>	<input type="checkbox"/>
10	Ensure that all safety signs and warning labels are fixed and visible.	<input type="checkbox"/>	<input type="checkbox"/>
11	Check if the connector protective sleeve is locked after the installation of the AC circular plug.	<input type="checkbox"/>	<input type="checkbox"/>

Commissioning Steps

- STEP 1:** Turn the DC switch on the inverter to "ON".
- STEP 2:** If a DC switch is equipped between the inverter and the PV string, close the switch.
- STEP 3:** If an AC switch is equipped between the inverter and the grid, close the switch.
- STEP 4:** If a DC switch is equipped between the inverter and the batteries, close the switch.
- STEP 5:** The inverter will operate normally if the sunlight is normal and the grid conditions meet the grid-connection requirements.
- STEP 6:** Observe the status of LED indicators (see "LED Indicators" for details).

Data Monitoring

- If you are a home user of photovoltaic power station, it is recommended to use the APP Smart M. You can download the APP by scanning the following QR code on your mobile phone, or searching for "Smart M" in the App Store (Android or iPhone).
- You can also log in to <https://global.slenergytech.com> for data searching.

