

Hybrid Inverter

SL-D4-12KTR-H25

Residential | Three phase | HV Battery | 2 MPPTs



98.2%
Max. Efficiency

15A
PV Input Current

10ms
UPS-level Switching

110%
Unbalanced Load



1

Talented

- 98.2% max. efficiency
- 135-750V super wide battery voltage range
- Within 10ms UPS-level switching
- Max. 15A PV input current

2

Powerful

- Up to 110% unbalanced load
- Up to 125% AC output overloading
- Max. 150% back-up output overloading @60s
- Parallel operation capacity with max. 10 units

3

Reliable

- IP65 protection degree
- Compact and elegant design with integrated die-casting technology
- Long-term efficient operation with advanced heat dissipation design

4

Friendly

- Convenient installation and O&M with horizontal design and quick plug terminals
- Easy data check via both OLED display and App
- Intelligent energy management with Slenergy built-in EMS
- Easy Wifi configuration via App
- Ideal for residential application with low operating noise

Circuit Diagram

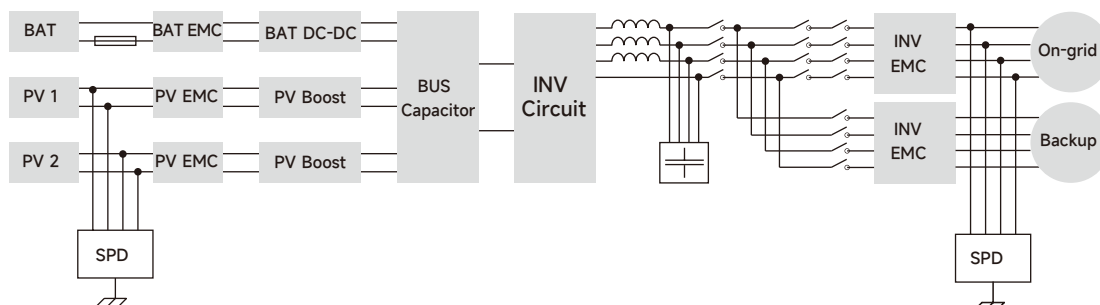

	SL-D4K TR-H25	SL-D5K TR-H25	SL-D6K TR-H25	SL-D8K TR-H25	SL-D10K TR-H25	SL-D12K TR-H25
PV Input						
Max. Input Power (kW)	6.0	7.5	9.0	12.0	15.0	18.0
Start-up Voltage	135	135	135	135	135	135
Max. DC Input Voltage (V)*	1000	1000	1000	1000	1000	1000
Rated DC Input Voltage (V)	620	620	620	620	620	620
MPPT Voltage Range (V)**	120-950	120-950	120-950	200-950	200-950	200-950
No. of MPP Trackers	2	2	2	2	2	2
No. of DC Inputs per MPPT	1/1	1/1	1/1	1/1	1/1	1/1
Max. Input Current (A)	15/15	15/15	15/15	15/15	15/15	15/15
Max. Short-circuit Current (A)	20/20	20/20	20/20	20/20	20/20	20/20
Battery Side						
Battery Type	Lithium Battery (with BMS)					
Battery voltage range (V)	135-750					
Maximum charging/discharge current (A)	25/25					
Grid Side						
Rated Output Power (kW)	4.0	5.0	6.0	8.0	10.0	12.0
Max. Output Apparent Power	4.4	5.5	6.6	8.8	11.0	13.2
Max. Input Apparent Power (kVA)***	8.0	10.0	12.0	16.0	16.5	16.5
Max. Charging Power of battery (kW)	4.0	5.0	6.0	8.0	10.0	12.0
Rated AC Voltage (V)	3L/N/PE; 220/380; 230/400; 240/415					
Rated AC Frequency (Hz)	50/60	50/60	50/60	50/60	50/60	50/60
Max. Output Current (A)	6.7	8.3	10.0	13.3	16.5	20.0
Adjustable Power Factor	0.8 leading ... 0.8 lagging					
Max. Total Harmonic Distortion	<3% @Rated output power					
DCI	<0.5%In	<0.5%In	<0.5%In	<0.5%In	<0.5%In	<0.5%In
Back-up Side						
Rated Output Power (kW)	4.0	5.0	6.0	8.0	10.0	12.0
Max. Output Apparent Power (kVA)	4.4	5.5	6.6	8.8	11.0	13.2
Max. Output Current (A)	6.7	8.3	10.0	13.3	16.5	20.0
UPS Switching Time	<10ms	<10ms	<10ms	<10ms	<10ms	<10ms
Rated Output Voltage (V)	3L/N/PE; 220/380; 230/400; 240/415					
Rated Output Frequency (Hz)	50/60	50/60	50/60	50/60	50/60	50/60
Peak Output Apparent Power (kVA)****	6, 60s	7.5, 60s	9, 60s	12, 60s	15, 60s	18, 60s
Voltage Harmonic Distortion	<3% @Linear load					
Efficiency						
Max. Efficiency	98.1%	98.1%	98.1%	98.2%	98.2%	98.2%
European Efficiency	97.3%	97.3%	97.3%	97.4%	97.4%	97.4%
Compliance IEC/EN 62109, IEC/EN 61000, EN50549-1, TOR Generator Type A, VDE-AR-N-4105						

Protection	
DC Reverse Polarity Protection	Integrated
Battery Input Reverse Connection Protection	Integrated
Insulation Resistance Protection	Integrated
Surge Protection	Integrated
Over-temperature Protection	Integrated
Residual Current Protection	Integrated
Islanding Protection	Integrated
AC Over-voltage Protection	Integrated
Overload Protection	Integrated
AC Short-circuit Protection	Integrated

General Data	
Over Voltage Category	PV: II; Main: III
Dimensions (W×H×D mm)	534×418×210
Weight (kg)	26.0
Protection Degree	IP65
Standby Self-consumption (W)	<15
Topology	Transformerless
Operating Temperature Range (°C)	-30~60
Relative Humidity (%)	0-100
Operating Altitude (m)	3000 (>3000m derating)
Cooling	Natural Convection
Noise Level (dB)	<25
Display	OLED & LED
Communication	CAN, RS485, WiFi/LAN (Optional)

*Max. operating DC voltage is 950V, max. withstanding DC voltage is 1000V

**The maximum MPPT voltage and operating voltage upper limit will be reduced to 900 V when inverter connects and works with battery

*** Max apparent power from the grid means the maximum power imported from the utility grid used to satisfy the backup loads and charge the battery

**** The output power will exceed the rated value only when the power in the PV array is sufficient, and the duration of the overload is related to the overload power